



Flex Pendant Arm Mount Quick Start Guide

© 2017 Tyco Security Products. All Rights Reserved

November 2017

Use the Illustra Flex Pendant Arm Mount (IFPTZWARM) to wall mount the Illustra Flex indoor or outdoor camera.

Mounting the indoor camera requires the use of a pendant cap (IFPTZIWPCAP) in conjunction with the pendant arm mount.

The Illustra Flex Pendant Arm Mount can be used with the following cameras:

Illustra Flex camera model description	Product code
Illustra Flex 2MP 20x PTZ indoor, white,TDN, WDR	IFS02P5ICWTY
Illustra Flex 2MP 20x PTZ, outdoor, white, TDN, WDR	IFS02P5OCWTY

The box contains the following items:

1. Pendant Arm Mount IFPTZWARM
2. 8200-1361-02 Illustra Flex Pendant Arm Mount Quick Start Guide
3. Sponge ball
4. Installation kit

Note: The installation kit includes the following parts:

- SPRING LOCK WASHER 8.0MM 13.8MM 1.9MM
- Stainless Steel Anchor OD10 X 45mm *4 pcs
- M8 Machine Screw X 60mm*4 pcs
- M8 Nut*4 pcs
- SPRING LOCK WASHER (8.0MM 13.8MM 1.9MM) *4pcs QIG*1pcs

To mount the camera using the Pendant Arm Mount, you need the following items:

- Flex camera
- Power cable
- Ethernet cable
- Pendant arm mount
- Installation kit
- Waterproof rubber
- Screws and screw anchors for fixing the pendant arm mount onto the ceiling
- Drilling tool
- Screwdriver
- Illustra Flex PTZ indoor pendant cap (optional)

Bubble Handling and Cleaning

Dome camera bubbles require special care when handling and cleaning to avoid scratches.

Handling

The bubble is packaged with a protective plastic sheet. It is recommended that the bubble remain stored this way until it is ready to install. Limit handling the bubble, as any scratches can quickly affect visibility. Always handle the dome by the outside edge of the trim ring or flange. Never contact the surface of the bubble.

Cleaning

If cleaning the bubble is required, use the following procedures and comply with all the warnings listed below.

Removing Dust and Dirt

The extremely soft bubble surfaces should not be cleaned by rubbing or dusting with a cloth. Use clean dry compressed air, preferably from a spray can, or Lens Cleaning Rubber Air Dust Blowing Ball to remove any dust from the interior surface.

Cleaning the Bubble

If heavy residue (spots, streaks, stains) or any other contaminants are present, first flush with clean water to remove any remaining dust or dirt. Then clean with a solution of a mild liquid dish detergent and water and lint free soft paper towels or a microfiber eyeglass cleaning cloth. After cleaning, the affected area of the dome should be blown off with clean, dry air.



Alcohol or ammonia based solutions should be avoided when cleaning the bubble as they will cause the bubble to cloud and over time cause stress aging, which makes the bubble brittle. However, if alcohol is required to remove residue, dilute with water and flush afterwards with pure water.

Excessive pressure or rubbing on the dome's surface can cause permanent scratches which may render the dome unusable.

Do not use abrasive or harsh chemical cleaners.

In order to mount the Indoor model of the Flex PTZ camera using the pendant arm mount, you need to use the 1 ½ female NPT threaded pendant cap.

Note:

The pendant cap comes with the outdoor model of the camera, but needs to be ordered separately for the indoor model of the camera.



Figure 1. NPT Pendant Cap

Mounting the Flex camera using the Pendant Arm Mount

To mount the camera using the Pendant Arm Mount, refer to Figure 1 while completing the following steps:

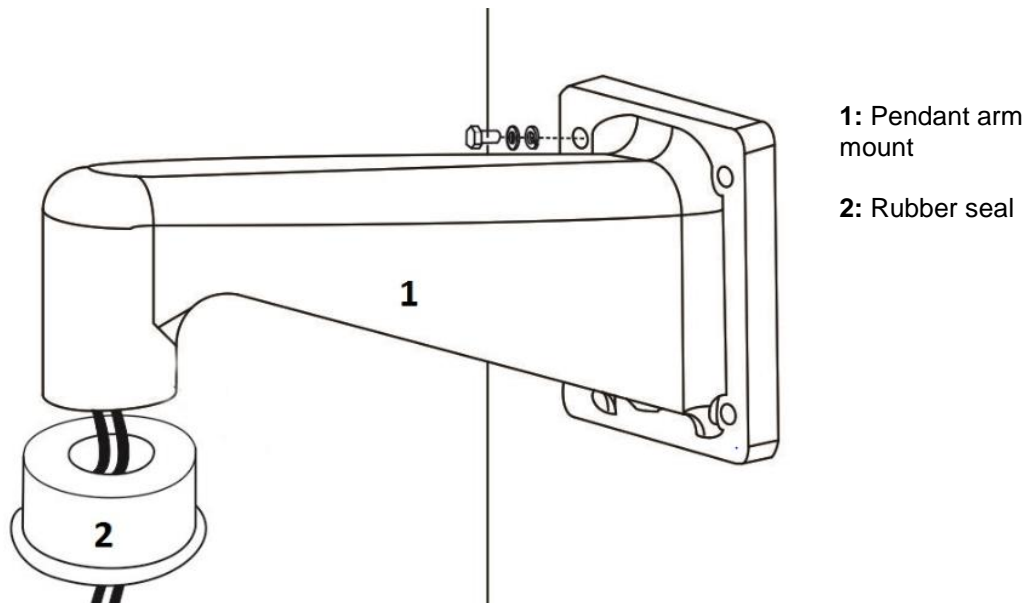

Figure 2. Pendant arm mount with rubber seal attached

1. Attach the rubber seal to the pendant arm mount.
2. Thread the pendant cap watertight onto the pendant arm mount.
3. Lower the rubber seal around the joint.
4. Drill a cable entry hole on the wall.
5. Depending on the wall type, secure the Pendant to the wall with the screws and anchors provided.
6. Feed the cables through the pendant arm mount.
7. Block the cable entry hole with the supplied sponge to prevent insects entering the pendant mount.
8. For safety and convenience, use the lanyard to connect the pendant arm mount and the camera.
9. Connect the cables to the camera.
10. Attach the camera to the Pendant Cap and lock it in place with the locking screws provided.

Contact Information

If you have any questions regarding these release notes, please contact Tyco Security Products Technical Services at:

Toll Free: 800-507-6268, Option 2 **International:** 561-912-6259, Option 2 **Alternative Number:** 800-392-2873

Fax: 450-444-2029

Hours: 08:00 – 20:00 EST

Email: adtechservices@tycoint.com

Website: www.americandynamics.net

www.illustracameras.com

In Europe, Middle East and Africa, contact Technical Support at:

Toll Free: +800 CALLTYCO or +800-2255 8926

Direct: +31 475 352 722

Hours: 08:00 – 18:00 CET

Email: : EMEA-Video-Support@tycoint.com

Website: www.tycosecurityproductsemea.com

Website: www.calltyco.com

Local Direct dial numbers:

UK	08701 238 787	Bahrain	800 04127
France	0800 90 79 72	Greece	00800 31 229 453
Spain	900 99 39 61	Russia	810 800 20 521 031
Germany	0800 1806 757	Turkey	00800 31 923 007
Italy	0800 874 091	United Arab Emirates	800 0310 7123
Belgium	0800 76 452	Israel	03 345 6868
Ireland	021 480 1122		

In Latin America and Caribbean, contact Technical Support at:

Southern Latin America

Contact: Cesar Cristal

Phone: +54-11-4711-8711

Cell: +54911-6452-7573

Email: ccristal@tycoint.com

Brazil (North)

Contact: Wagner Soares

Phone: +55 (21) 2108-6016
x.250

Cell: +55 (21) 99153-3519

Email: wsoares@tycoint.com

Brazil (South)

Contact: Dani Hissnauer Miguel

Phone: +55 (11) 2172 9224

Cell: +55 (11) 97663-2653

Email: danimiguel@tycoint.com

Northern Latin America & Caribbean

Contact: Hildebrando Duran

Phone: +57-1638-6278

Cell: +57-317668-9590

Email: hiduran@tycoint.com

Mexico

Contact: Marco Antonio Salguero

Phone: +52-55-5488-8092

Cell: +52-55-1473-4946

Email: msalguero@tycoint.com

In Asia Pacific, contact Technical Support at:

Toll Free: +800 CALLTYCO or +800-2255 8926

Direct: +86 21 60 23 0650

China Only Hotline: 400 671 1528

India Only Hotline: 1 800 1082 008

Hours: 08:00 – 17:00 CST

Email: apac.support@tycoint.com

Information furnished by Tyco Security Products is believed to be accurate and reliable. However, no responsibility is assumed by Tyco Security Products for its use, nor any infringements of other rights of third parties which may result from its use. No license is granted by implications or otherwise under any patent rights of Tyco Security Products.
